

PARTS LIST			
ITEM	QTY	PART NUMBER	DESCRIPTION
1	1	SWS-1019-12-13	FEED BOX
2	1	SWS-1054-12-13	WEAR LINER

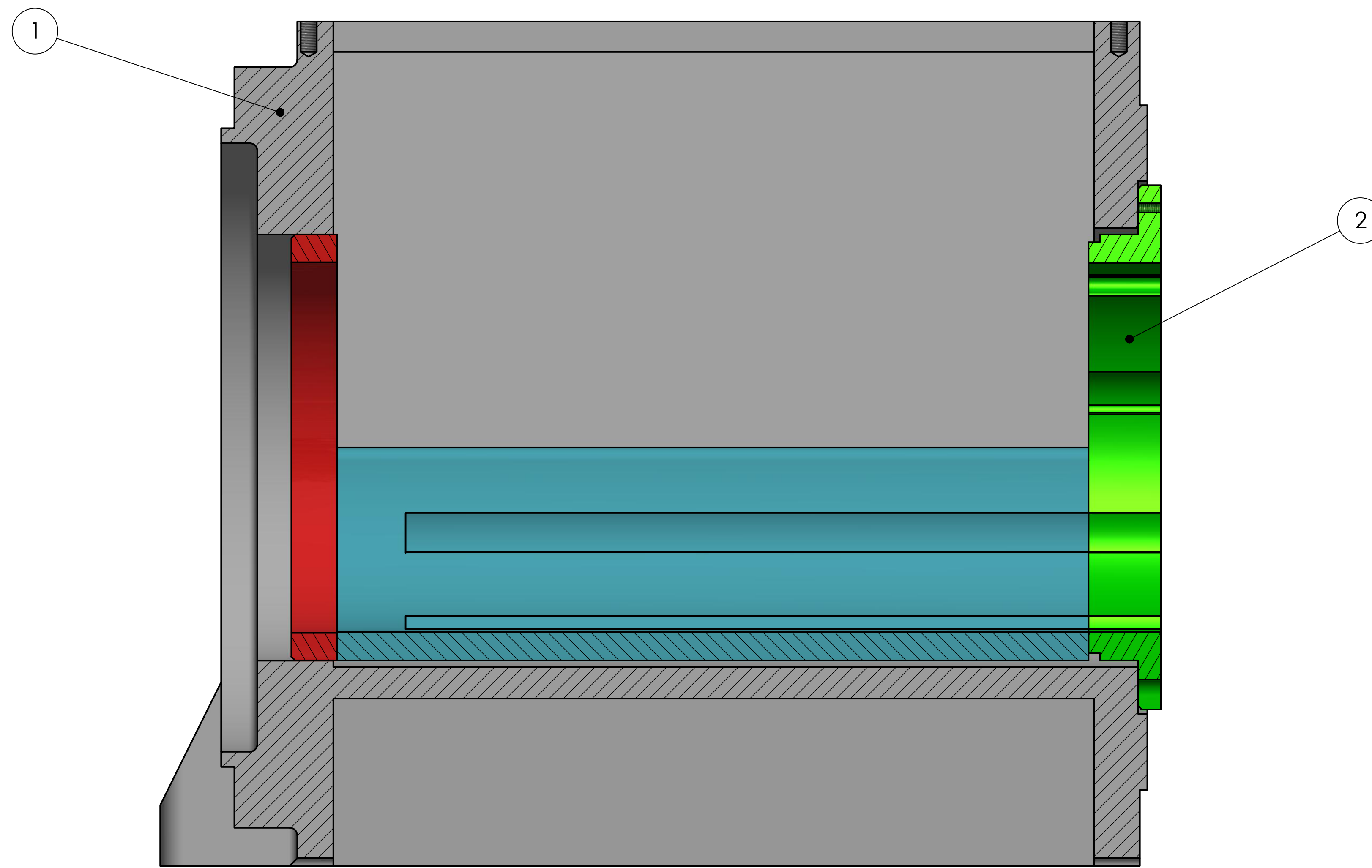

SECTION A-A

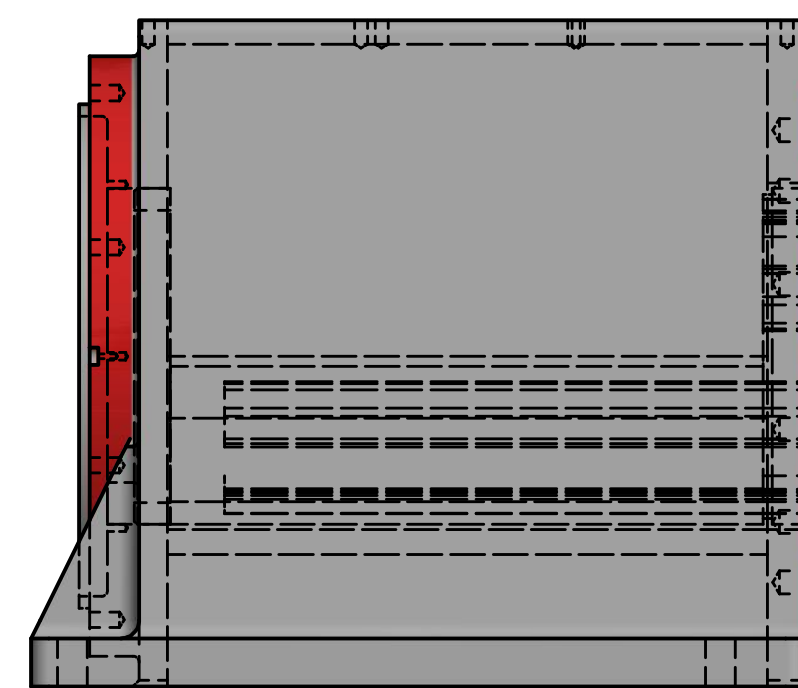
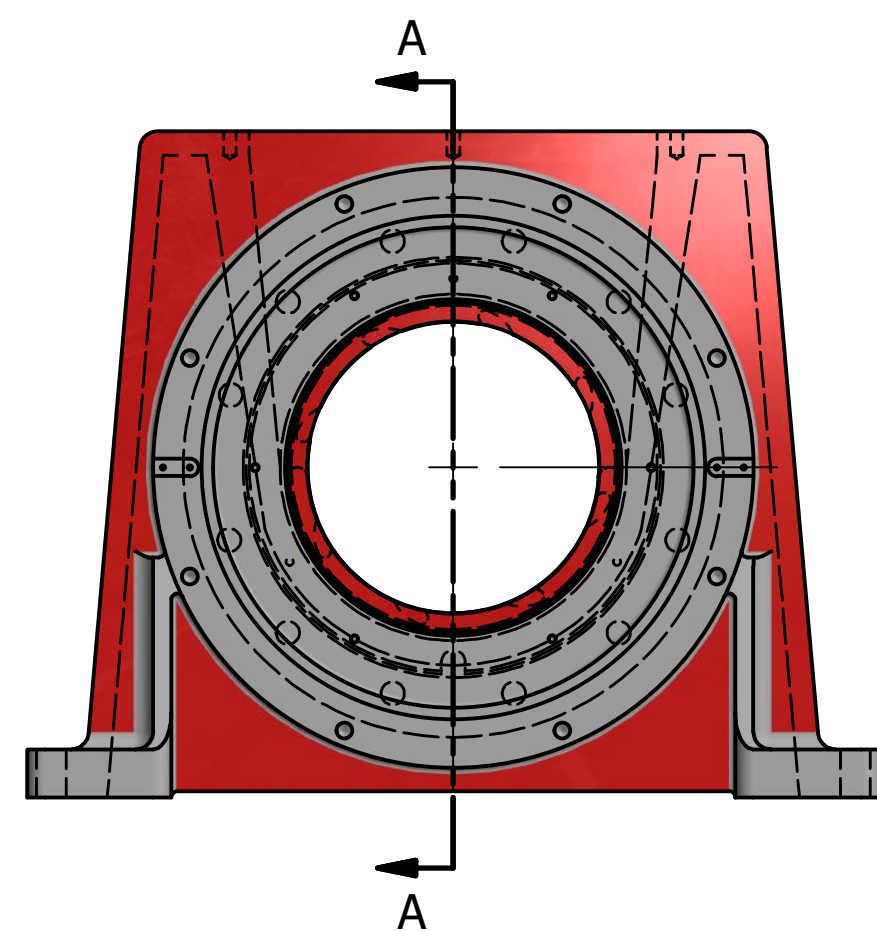
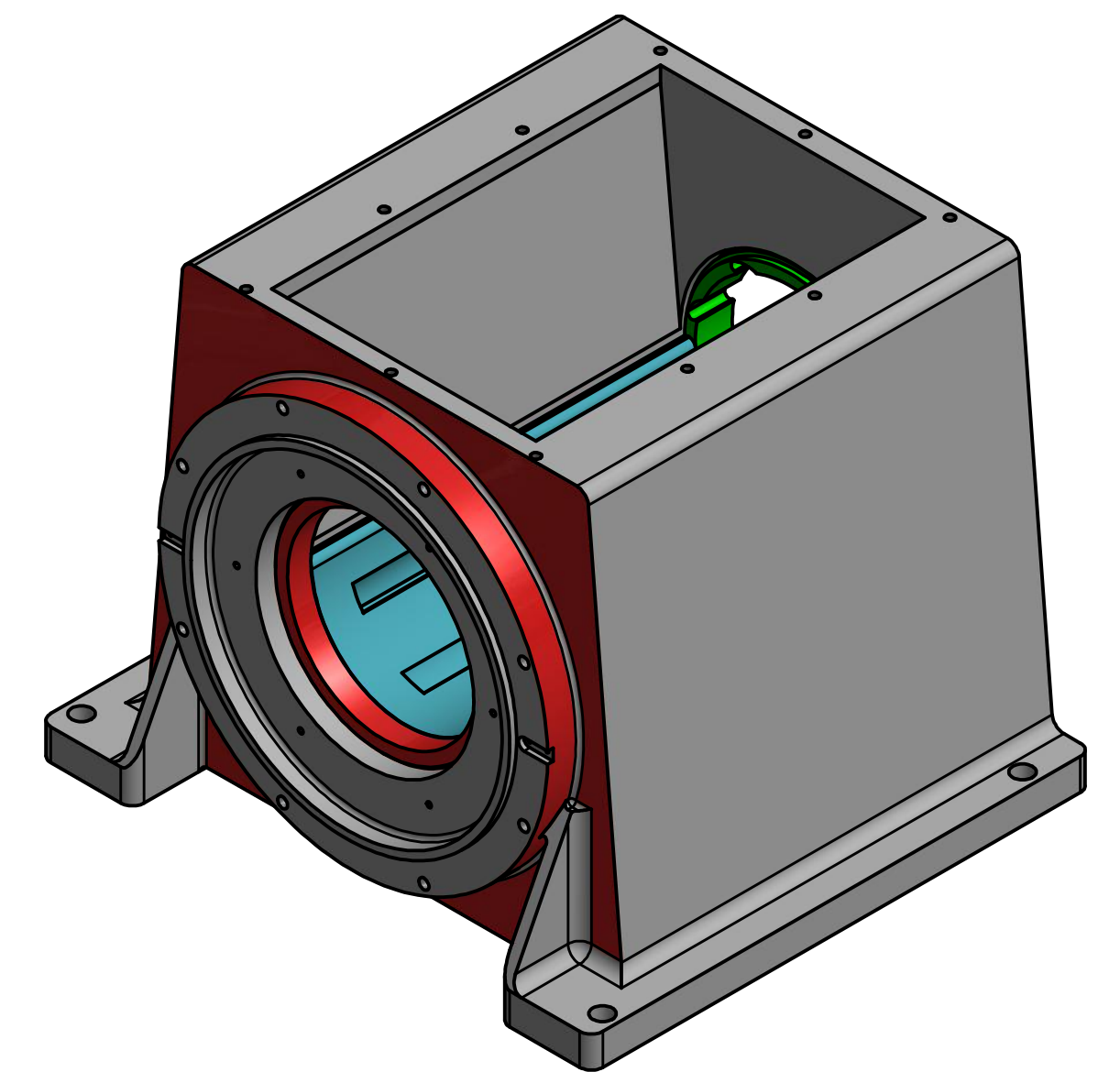

STATUS:	CERTIFIED 05-07-14	The information contained herein is confidential and proprietary information belonging exclusively to Refiner Products Manufacturing, Inc. and shall not be used or reproduced in any manner, or disclosed to others without the written permission of Refiner Products Manufacturing, Inc.	DRAWN B.WILSON	4/9/2014	 P.O. BOX 471335 - CHARLOTTE, N.C. 28226 - USA - (704) 602-3070 ANDRITZ FEED BOX ASSEMBLY
MATERIAL:		MACHINING TOLERANCES UNLESS OTHERWISE NOTED	CHECKED		
CUSTOMER:		125 STANDARD MACHINE FINISH	QA		
REFERENCE:		REMOVE ALL BURRS BREAK OUTSIDE EDGES	MFG		TITLE
		FRACTIONAL = ± 1/64"	APPROVED		SIZE
		DECIMAL = ± .005"			DWG NO
		ANGLE = ± 1/2°			SWS-1019-13
					REV
					0
					SCALE
					SHEET 1 OF 1