

SECTION C-C

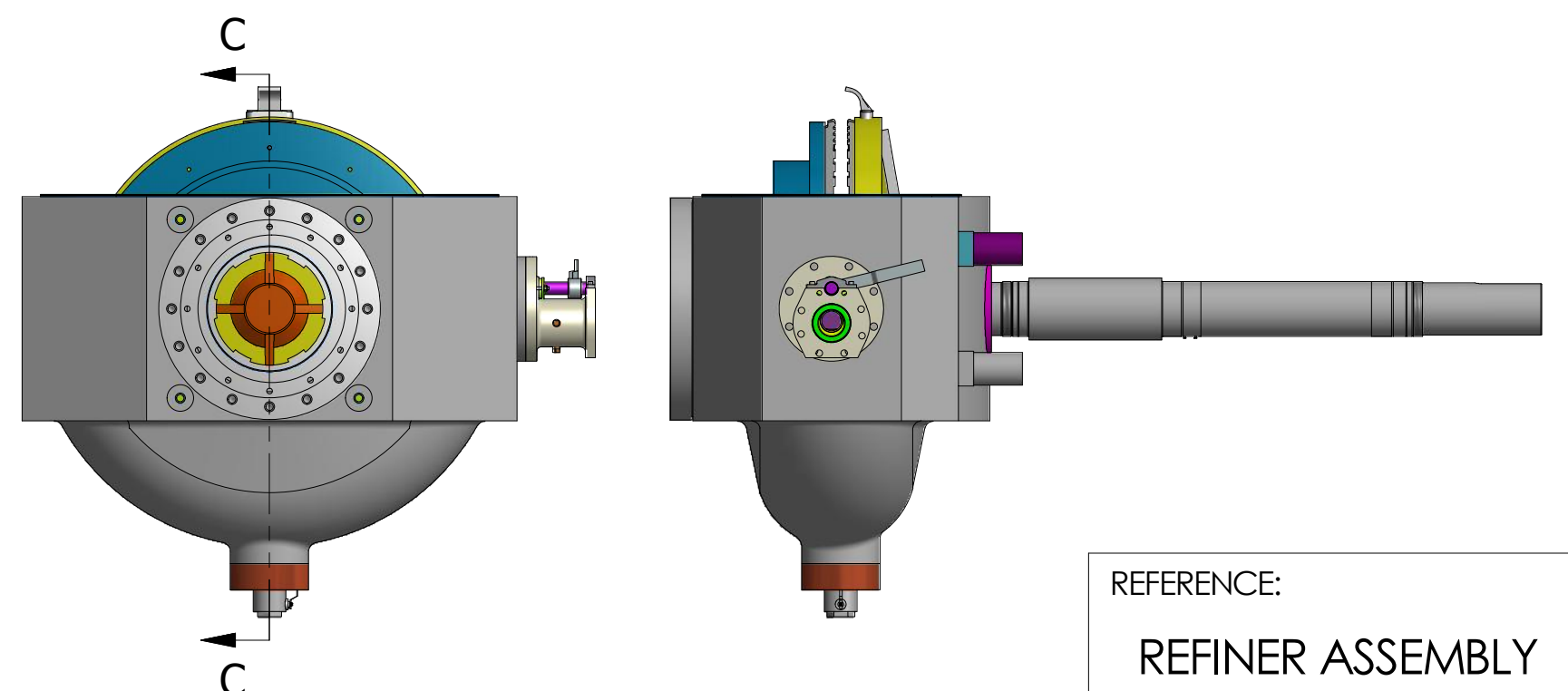

REFERENCE:
REFINER ASSEMBLY

		PARTS LIST	
ITEM	QTY	PART NUMBER	DESCRIPTION
1	1	42-1CP	REFINER HOUSING
2	1	SWR-1002-42	DISC PLATE HOLDER, ROTOR
3	1	SWR-1007-42	HOUSING INSERT
4	1	SWR-1003-42	PLATE HOLDER, STATOR
5	4	SWR-1286-42-42M.005	REFINER PLATE
6	1	SWR-1010-42	MECHANICAL SEAL
7	1	SWR-1094-42-46	NUT, FLINGER
8	1	SDR-1077-42-46	BLOW VALVE
9	1	SWR-1286-42-42M.009	DRAIN VALVE
10	1	SWR-1097-42	MAIN SHAFT
11	1	SWR-1286-42-42M.011	KEY, ROTOR
12	2	SWR-1252-42	ROTOR VANE
13	1	SWR-1286-42-42M.013	GASKET, COVER
14	1	SWR-1286-42-42M.014	CLEANER
15	48	SWR-1286-42-42M.015	HEX CAP SCREW 1/2-13 UNC - 1.25" LG.
16	48	SWR-1286-42-42M.016	WASHER 1/2"
17	2	SWR-1286-42-42M.017	100° Flat CS Machine Screw 10-24 UNC x 0.75" LG.
18	6	SWR-1286-42-42M.018	HEX SHCS 1/2 - 13 UNC - 1 1/4" LG.
19	2	SWR-1286-42-42M.019	HEX SHCS 3/4 - 10 UNC - 1 3/4" LG.
20	2	SWR-1286-42-42M.020	LOCK WASHER 3/4
21	1	SWR-1286-42-42M.021	SEAL KIT

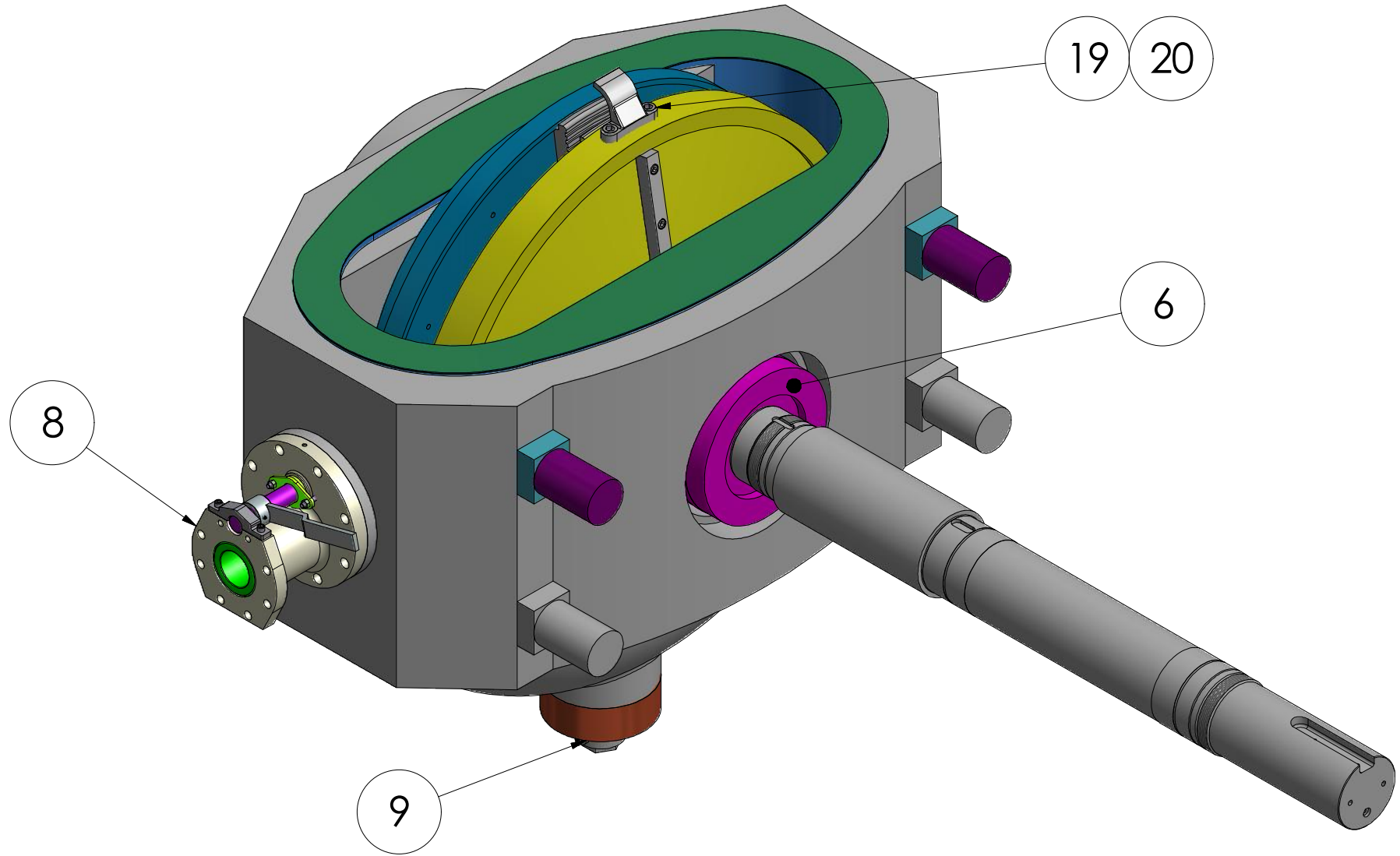

STATUS: **CERTIFIED**

MATERIAL:

CUSTOMER:

The information contained herein is confidential and proprietary information belonging exclusively to Refiner Products Manufacturing, Inc. and shall not be used or reproduced in any manner, or disclosed to others without the written permission of Refiner Products Manufacturing, Inc.

MACHINING TOLERANCES UNLESS OTHERWISE NOTED

125 STANDARD MACHINE FINISH

**REMOVE ALL BURRS
BREAK OUTSIDE EDGES**

FRACTIONAL = ± 1/64"
DECIMAL = ± .005"
ANGLE = ± 1/2"

DRAWN	11/15/2013
CHECKED	
QA	
MFG	
APPROVED	

RPM
Refiner Products Manufacturing
P.O. BOX 471335 - CHARLOTTE, N.C. 28226 - USA - (704) 602-3070

TITLE: **GRINDING HOUSING ASSEMBLY**

SIZE	DWG NO	REV
D	SWR-1286-42	0
SCALE	SHEET 1 OF 1	